

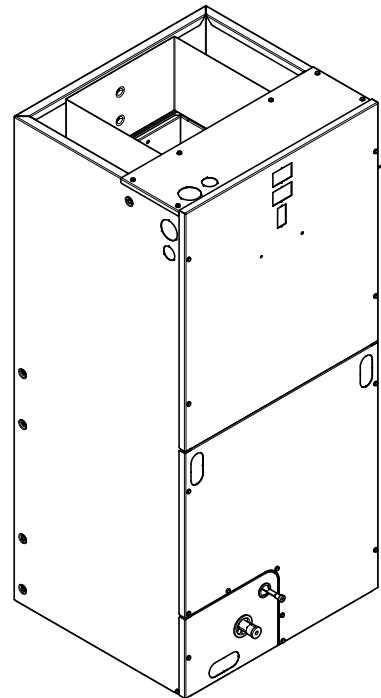

Submittal

3 Ton Convertible Air Handler TEM3A0B36S31SA



TAG: _____

⚠ SAFETY WARNING

Only qualified personnel should install and service the equipment. The installation, starting up, and servicing of heating, ventilating, and air-conditioning equipment can be hazardous and requires specific knowledge and training. Improperly installed, adjusted or altered equipment by an unqualified person could result in death or serious injury. When working on the equipment, observe all precautions in the literature and on the tags, stickers, and labels that are attached to the equipment.

Outline Drawing

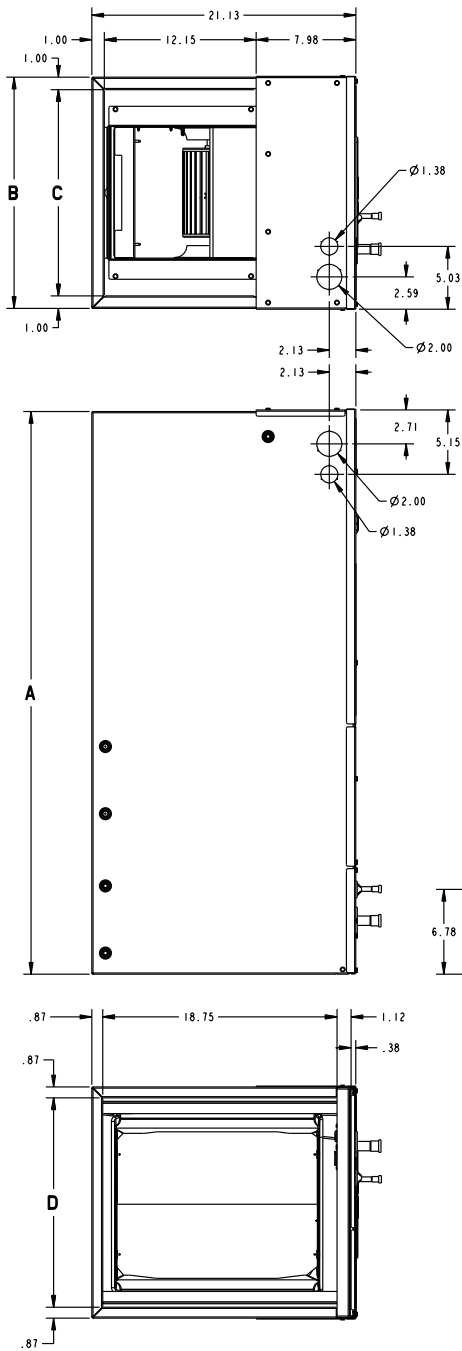

MINIMUM UNIT CLEARANCE TABLE		
	TO COMBUSTIBLE MATERIAL (REQUIRED)	SERVICE CLEARANCE (RECOMMENDED)
SIDES	0"	2"
FRONT	0"	21"
BACK	0"	0"
INLET DUCT	0"	1"
OUTLET DUCT	1"+	N/A

* 1" FOR THE FIRST 3 FT. OF OUTLET DUCT WHEN ELECTRIC HEATERS ARE INSTALLED: 0" AFTER THE FIRST 3 FT.

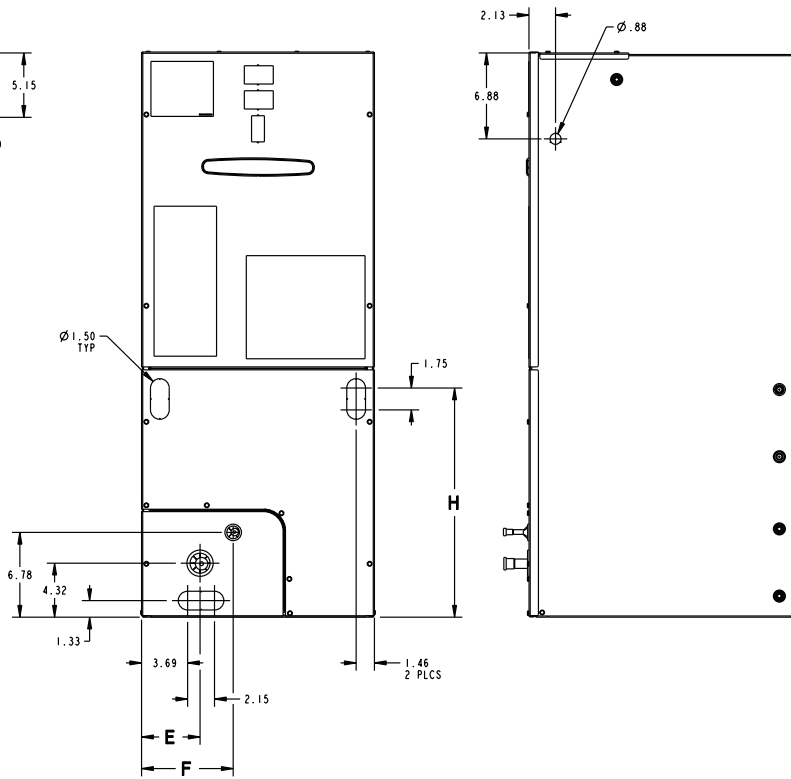

PRODUCT DIMENSIONS									
Air Handler Model	A	B	C	D	E	F	H	Flow Control	Gas Line Braze
TEM3A0B36S31SA	45.02	18.50	16.50	16.75	4.68	7.33	18.34	TXV	3/4

All dimensions are in inches



Product Specifications

MODEL	TEM3A0B36S31SA
RATED VOLTS/PH/HZ	208-230/1/60
RATINGS^(a)	See O.D. Specifications
INDOOR COIL — Type	Plate Fin
Rows — F.P.I.	3 - 14
Face Area (sq. ft.)	4.37
Tube Size (in.)	3/8
Refrigerant Control	TXV
Drain Conn. Size (in.) ^(b)	3/4 NPT
DUCT CONNECTIONS	See Outline Drawing
INDOOR FAN — Type	Centrifugal
Diameter-Width (In.)	10 X 8
No. Used	1
Drive - No. Speeds	Direct - 3
CFM vs. in. w.g.	See Fan Performance Table
No. Motors — H.P.	1 - 1/2
Motor Speed R.P.M.	1075
Volts/Ph/Hz	208-230/1/60
F.L. Amps	2.5
FILTER	
Filter Furnished? ^(c)	No
REFRIGERANT	R-410A
Ref. Line Connections	Brazed
Coupling or Conn. Size — in. Gas	3/4

Coupling or Conn. Size — in. Liq.	3/8
DIMENSIONS	H x W x D
Crated (In.)	46 x 21 x 24
Uncrated	45-31/8 x 18-1/2 x 21-1/8
WEIGHT	
Shipping (Lbs.) / Net (Lbs.)	116/110

(a) These Air Handlers are A.H.R.I certified with various Split System Air Conditioners and Heat Pumps (AHRI STANDARD 210/240). Refer to the Split System Outdoor Unit Product Data Guides for performance data.

(b) 3/4" Male Plastic Pipe (Ref: ASTM 1785-76)

(c) Remote filter required.

Minimum Airflow CFM

TEM3A0B36S31SA		
Heater	Minimum Heat Speed Tap	
	With Heat Pump	Without Heat Pump
BAYHTR1504BRK, BAYHTR1504PDC, BAYHTR1504LUG, BAYHTR1505BRK, BAYHTR1505PDC, BAYHTR1505LUG	Low	Low
BAYHTR1508BRK, BAYHTR1508PDC, BAYHTR1508LUG, BAYHTR1510BRK, BAYHTR1510PDC, BAYHTR1510LUG, BAYHTR3510LUG	Low	Low
BAYHTR1515BRK, BAYHTR3515LUG, BAYHTR1519BRK	Low	Low



Heater Pressure Drop Table TEM Air Handler Models

Airflow CFM	Number of Racks				Heater Racks	
	1	2	3	4	Heater Model	No. of Racks
	Air Pressure Drop — Inches W.G.					
1800	0.02	0.04	0.06	0.14	BAYHTR1504	1
1700	0.02	0.04	0.06	0.14	BAYHTR1505	1
1600	0.02	0.04	0.06	0.13	BAYHTR1508	2
1500	0.02	0.04	0.06	0.12	BAYHTR1510	2
1400	0.02	0.04	0.06	0.12	BAYHTR3510	3
1300	0.02	0.04	0.05	0.11	BAYHTR1515	3
1200	0.01	0.04	0.05	0.10	BAYHTR3515	3
1100	0.01	0.03	0.05	0.09	BAYHTR1519	4
1000	0.01	0.03	0.04	0.09	BAYHTR1520	4
900	0.01	0.03	0.04	0.08	BAYHTR1521	4
800	0.01	0.03				
700	0.01	0.02				
600	0.01	0.02				



Performance and Electrical Data

1. See Product Data or Air Handler nameplate for approved combinations of Air Handlers and Heaters.
2. Heater model numbers may have additional suffix digits.

Table 1. Air Flow Performance

TEM3A0B36S31SA (a) (b)						
EXTERNAL STATIC (in w.g)	AIRFLOW					
	Speed Taps — 230 VOLTS			Speed Taps — 208 VOLTS		
	High	Med	Low †	High	Med	Low †
0.1	1461	1336	979	1406	1173	834
0.2	1404	1291	971	1352	1152	819
0.3	1344	1242	962	1295	1121	810
0.4	1281	1188	944	1234	1081	804
0.5	1214	1130	916	1169	1035	791
0.6	1142	1066	876	1100	981	768
0.7	1066	997		1026	920	732

1. Values are with wet coil, no filter, and no heaters
 2. CFM Correction for dry coil = Add 3%
 3. † = Factory setting

(a) For the TEM3A0B36S31SA the recommended speed tap is medium at 0.4" external static pressure.

(b) For the TEM3A0B36S31SA in downflow applications, airflow must not exceed 1200 cfm due to condensate blow off.



Performance and Electrical Data

Table 2. Electrical Data

TEM3A0B36S31SA											
Heater Model No.	No. of Circuits/ Phases	240 Volt					208 Volt				
		Capacity		Heater Amps per Circuit	Minimum Circuit Ampacity	Maximum Overload Protection	Capacity		Heater Amps per Circuit	Minimum Circuit Ampacity	Maximum Overload Protection
		kW	BTUH				kW	BTUH			
No Heater				2.5 *	3	15			2.5 *	3	15
BAYHTR1504BRK BAYHTR1504PDC BAYHTR1504LUG	1/1	3.84	131-00	16.0	23	25	2.88	9800	13.8	20	20
BAYHTR1505BRK BAYHTR1505PDC BAYHTR1505LUG	1/1	4.8	164-00	20.0	28	30	3.6	12300	17.3	25	25
BAYHTR1508BRK BAYHTR1508PDC BAYHTR1508LUG	1/1	7.68	262-00	32.0	43	45	5.76	19700	27.7	38	40
BAYHTR1510BRK BAYHTR1510PDC BAYHTR1510LUG	1/1	9.6	328-00	40.0	53	60	7.2	24600	34.6	46	50
BAYHTR1515BRK- Circuit 1 ^(a)	2/1	9.6	328-00	40.0	53	60	7.2	24600	34.6	46	50
BAYHTR1515BRK- Circuit 2		4.8	164-00	20.0	25	25	3.6	12300	17.3	22	25
BAYHTR1519BRK- Circuit 1 ^(a)	2/1	9.6	328-00	40.0	53	60	7.2	24600	34.6	46	50
BAYHTR1519BRK- Circuit 2		9.6	328-00	40.0	50	50	7.2	24600	34.6	43	45
BAYHTR3510LUG	1/3	9.6	328-00	23.1	32	35	7.2	24600	20.0	28	30
BAYHTR3515LUG	1/3	14.4	492-00	34.6	46	50	10.8	36900	30.0	40	40
BAYHTR1515BRK with single circuit power source kit BAYSPEKT201A	1/1	14.4	492-00	60.0	83	90	10.8	36900	51.9	73	80
BAYHTR1519BRK with single circuit power source kit BAYSPEKT201A	1/1	19.2	655-00	80.0	108	110	14.4	49200	69.2	94	100

* = Motor Amps

^(a) MCA and MOP for circuit 1 contains the motor amps



Features and Benefits

- Painted metal cabinet with captured foil face insulation
- 2% or less air leakage
- R-4.2 Insulating Value
- Multi-Position UP/Down Flow, Horizontal Left /Right
- ALL Aluminum Coil with Enhanced Patented Coil Fin
- Electric Heaters with polarized plug connections (sold as accessory)
- R-410A Thermal Expansion Valve
- ECM Motor **(5 Ton Models Only)**
- Low Voltage Pigtail Connections
- Draw Through Design
- Horizontal Drain pan
- Single Color
- Fused 24V Power
- **1 year warranty**
- **10-year warranty registered**
- **Optional extended warranty available**

Important: Condensate management kit is required for all 5 ton air handler models installed in downflow applications.



Trane optimizes the performance of homes and buildings around the world. A business of Ingersoll Rand, the leader in creating and sustaining safe, comfortable and energy efficient environments, Trane offers a broad portfolio of advanced controls and HVAC systems, comprehensive building services, and parts. For more information, visit www.Trane.com.

Trane has a policy of continuous product and product data improvements and reserves the right to change design and specifications without notice.

©2014 Trane

TEM3A0B36-SUB-1C-EN 04 Jul 2014

Supersedes TEM3A0B36-SUB-1B-EN (May 2014)

