



TAG: \_\_\_\_\_

**SUBMITTAL**

NOTE: All dimensions are in mm/inches.

**4 Ton Split System Cooling – 1 Ph  
4TTX6049H**

**Product Specifications**

OUTDOOR UNIT ①②	4TTX6049H1000A
<b>POWER CONNS. — V/PH/HZ</b> ③	208/230/1/60
MIN. BRCH. CIR. AMPACITY	26
BR. CIR. PROT. RTG. – MAX. (AMPS)	45
<b>COMPRESSOR</b>	CLIMATUFF <sup>®</sup> - SCROLL
NO. USED - NO. SPEEDS	1 - 1
VOLTS/PH/HZ	208/230/1/60
R.L. AMPS ⑦ - L.R. AMPS	19.9 - 109
FACTORY INSTALLED	
START COMPONENTS ③	NO
INSULATION/SOUND BLANKET	NO
COMPRESSOR HEAT	NO
<b>OUTDOOR FAN</b>	PROPELLER
DIA. (IN.) - NO. USED	27.6 - 1
TYPE DRIVE - NO. SPEEDS	DIRECT - 1
CFM @ 0.0 IN. W.G. ④	4250
NO. MOTORS - HP	1 - 1/5
MOTOR SPEED R.P.M.	825
VOLTS/PH/HZ	200/230/1/60
F.L. AMPS	1.00
<b>OUTDOOR COIL — TYPE</b>	SPINE FIN <sup>™</sup>
ROWS - F.P.I.	1 - 24
FACE AREA (SQ. FT.)	30.79
TUBE SIZE (IN.)	3/8
<b>REFRIGERANT</b>	
LBS. — R-410A (O.D. UNIT) ⑤	11 LBS., 09 OZ.
FACTORY SUPPLIED	YES
LINE SIZE - IN. O.D. GAS ⑥	7/8
LINE SIZE - IN. O.D. LIQ. ⑥	3/8
<b>CHARGING SPECIFICATION</b>	
SUBCOOLING	8°F
<b>DIMENSIONS</b>	H X W X D
CRATED (IN.)	57.4 x 35.1 x 38.7
<b>WEIGHT</b>	
SHIPPING (LBS.)	324
NET (LBS.)	287

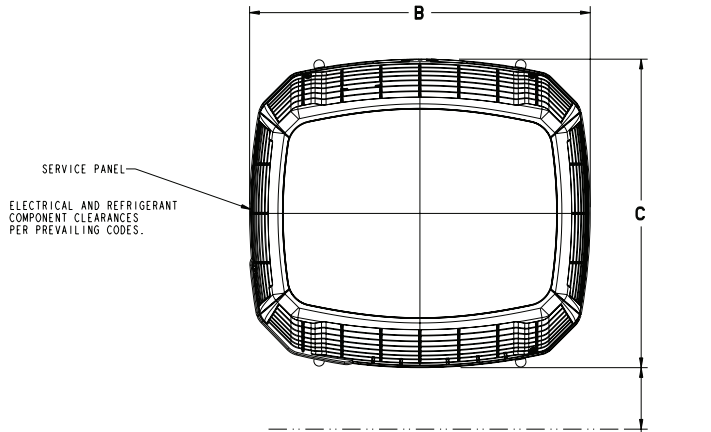

UNIT SHOULD BE PLACED SO ROOF RUN-OFF WATER DOES NOT POUR DIRECTLY ON UNIT, AND SHOULD BE AT LEAST 305 (12") FROM WALL AND ALL SURROUNDING SHRUBBERY ON TWO SIDES. OTHER TWO SIDES UNRESTRICTED.

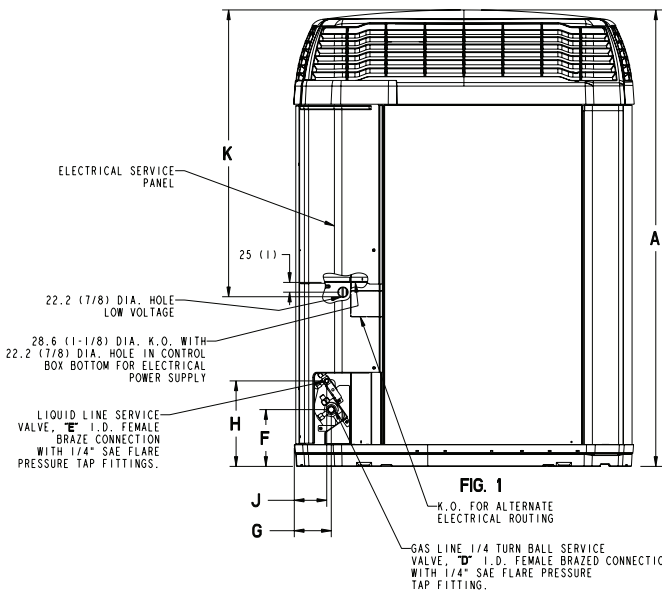

**FIG. 1**  
K.O. FOR ALTERNATE ELECTRICAL ROUTING  
GAS LINE 1/4 TURN BALL SERVICE VALVE; 1/2\"/>

From Dwg. D156010

MODELS	BASE	A	B	C	D	E	F	G	H	J	K
4TTX6049H	4	1369 (53 7/8)	946 (37-1/4)	870 (34-1/4)	7/8	3/8	152 (6)	98 (3-7/8)	219 (8-5/8)	86 (3-3/8)	730 (28-3/4)

- ① Certified in accordance with the Air-Source Unitary Air-conditioner Equipment certification program, which is based on AHRI standard 210/240.
- ② Rated in accordance with AHRI standard 270.
- ③ Calculated in accordance with Natl. Elec. Codes. Use only HACR circuit breakers or fuses.
- ④ Standard Air — Dry Coil — Outdoor
- ⑤ This value approximate. For more precise value see unit nameplate.
- ⑥ Max. linear length 60 ft.; Max. lift - Suction 60 ft.; Max lift - Liquid 60 ft.  
For greater length consult refrigerant piping software Pub. No. 32-3312-0\*  
(\* denotes latest revision).
- ⑦ This value shown for compressor RLA on the unit nameplate and on this specification sheet is used to compute minimum branch circuit ampacity and max. fuse size. The value shown is the branch circuit selection current.
- ⑧ No means no start components. Yes means quick start kit components. PTC means positive temperature coefficient starter.

**Sound Power Level**

Model	A-Weighted Sound Power Level [dB(A)]	Full Octave Sound Power [dB]							
		63 Hz	125 Hz	250 Hz	500 Hz	1000 Hz	2000 Hz	4000 Hz	8000 Hz
4TTX6049H1	72	70	70	65	64	62	56	49	42

Note: Rated in accordance with AHRI Standard 270-2008

# Mechanical Specification Options

## General

The 4TTX6 is fully charged from the factory for up to 15 feet of piping. This unit is designed to operate at outdoor ambient temperatures as high as 115°F. Cooling capacities are matched with a wide selection of air handlers and furnace coils that are AHRI certified. The unit is certified to UL 1995. Exterior is designed for outdoor application.

## Casing

Unit casing is constructed of heavy gauge, G90 galvanized steel and painted with a weather-resistant powder paint on all louvers, panels, prepaint on all other panels. Corrosion and weatherproof CMBP-G30 DuraTuff™ base.

## Refrigerant Controls

Refrigeration system controls include condenser fan and compressor contactor. High and low pressure controls are inherent to the compressor. A factory installed liquid line drier is standard.

## Compressor

The Climatuff® compressor features internal over temperature and pressure protection and total dipped hermetic motor. Other features include centrifugal oil pump and low vibration and noise.

## Condenser Coil

The outdoor coil provides low airflow resistance and efficient heat transfer. The coil is protected on all four sides by louvered panels.

## Low Ambient Cooling

As manufactured, this unit has a cooling capability to 55°F. The addition of an evaporator defrost control with TXV permits low ambient cooling to 30° F.

## Accessories

Thermostats — Cooling only and heat/cooling (manual and automatic changeover). Sub-base to match thermostat and locking thermostat cover.

